

PORTABLE HOISTER

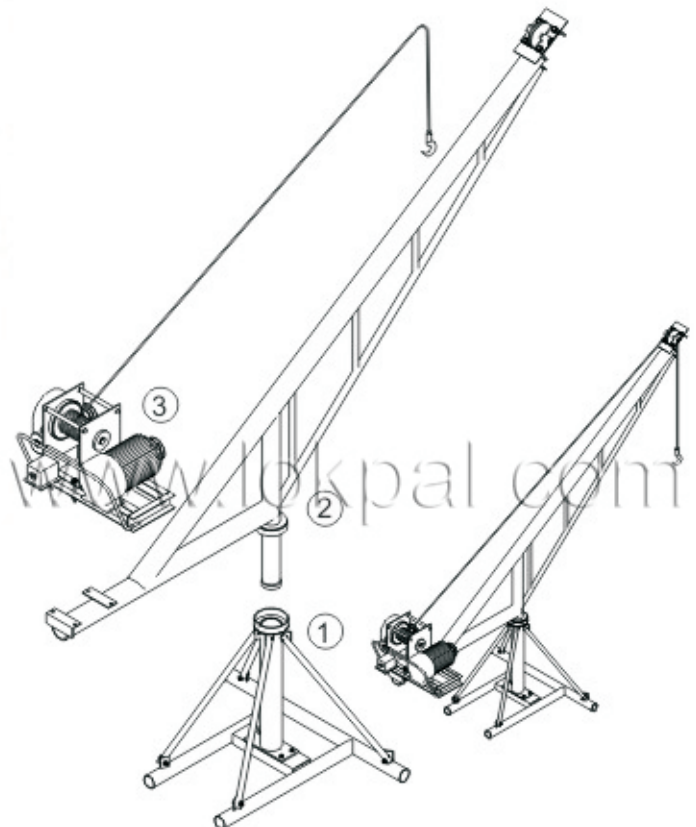

For use in small construction sites.
Easy to move floor to floor.
Very Portable and light weight.



Specifications:

Capacity	200Kg
Motor	3Kw, 3Phase
Lifting Height	60 Feet
Wire Rope	8 mm
Gear box	36:1
Rotation	360°

Convenient Light weight
3 piece design can be easily
dismantled and carried from
floor to floor

LOKPAL INDUSTRIES

A-6, Sector-3, Noida-201301, U.P., India | Tel.: +91-120-3065372 / 75

Website: www.lokpal.com | E-mail: info@lokpal.com